

Disk Scheduling

Components of a Disk

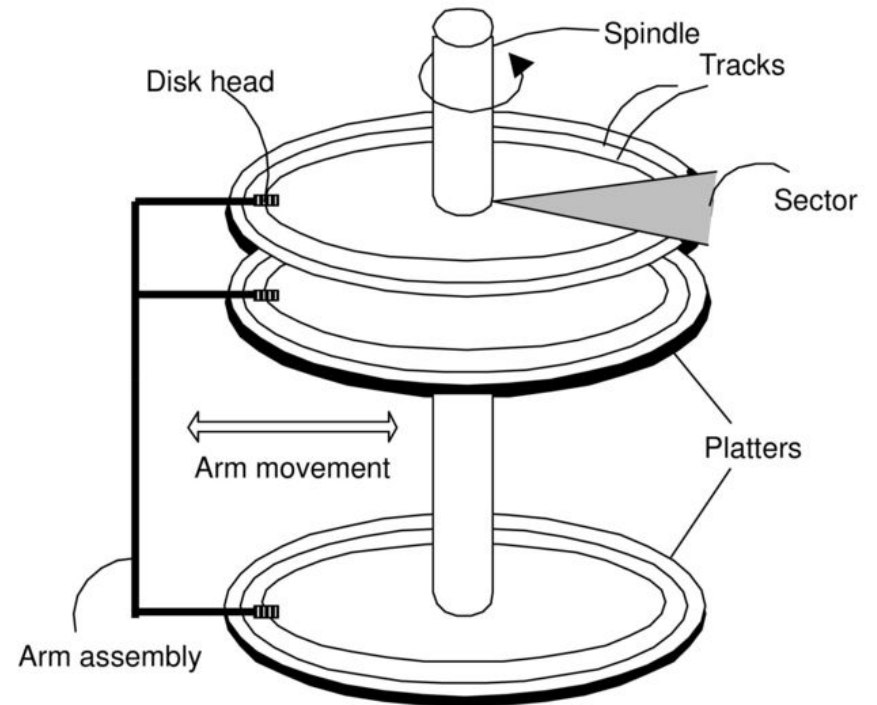

Usage time

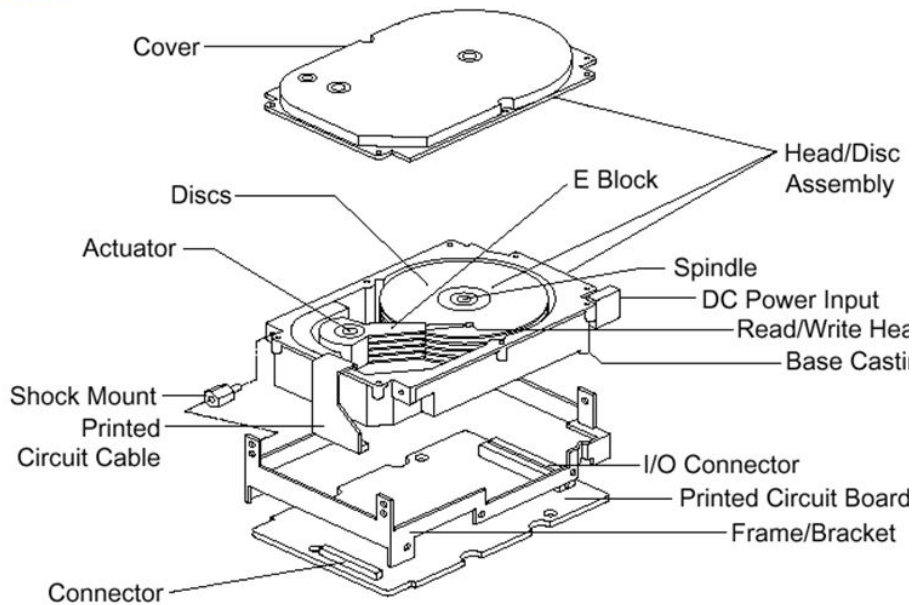
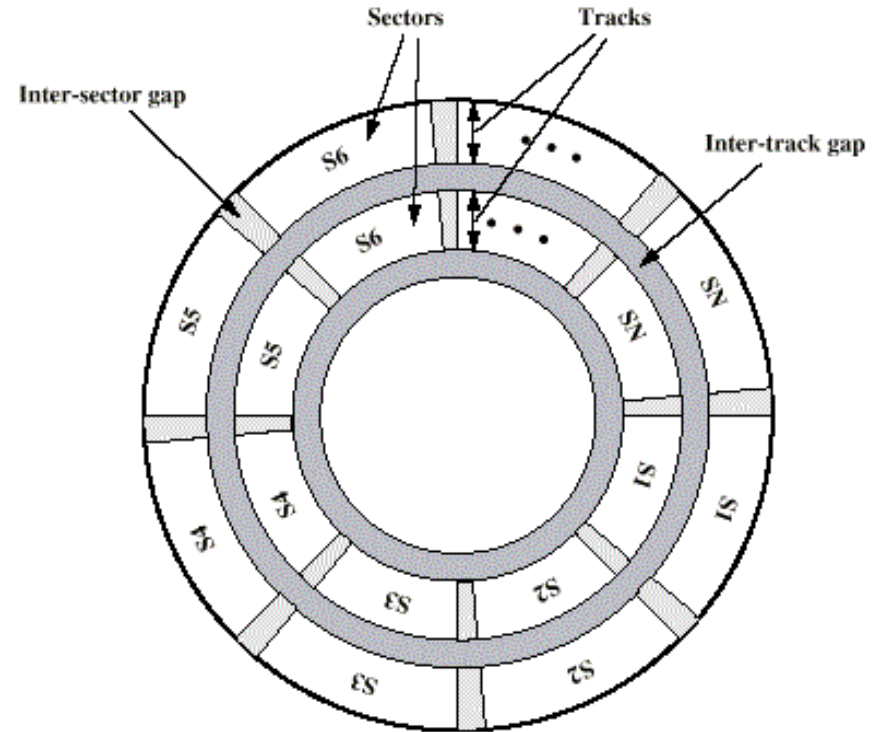
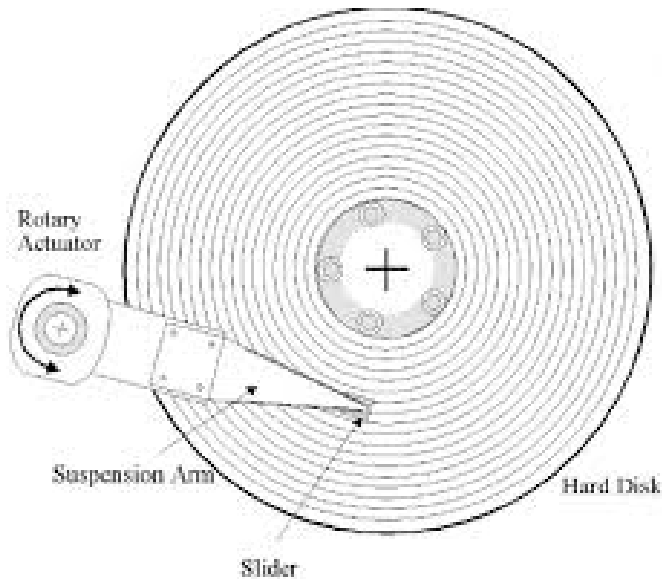

- Seek time
- Rotational time (Rotational latency)

Access time = Seek time + Rotational time

Usage time



- Bandwidth
= **total bytes/total time**

Disk Scheduling algorithms

- **First Come First Served : FCFS**
- **Shortest Seek Time First : SSTF**
- **SCAN**
- **C-SCAN**
- **LOOK**
- **C-LOOK**

Disk Scheduling algorithms

- **First Come First Served : FCFS**

Illustration shows total head movement of 640 cylinders

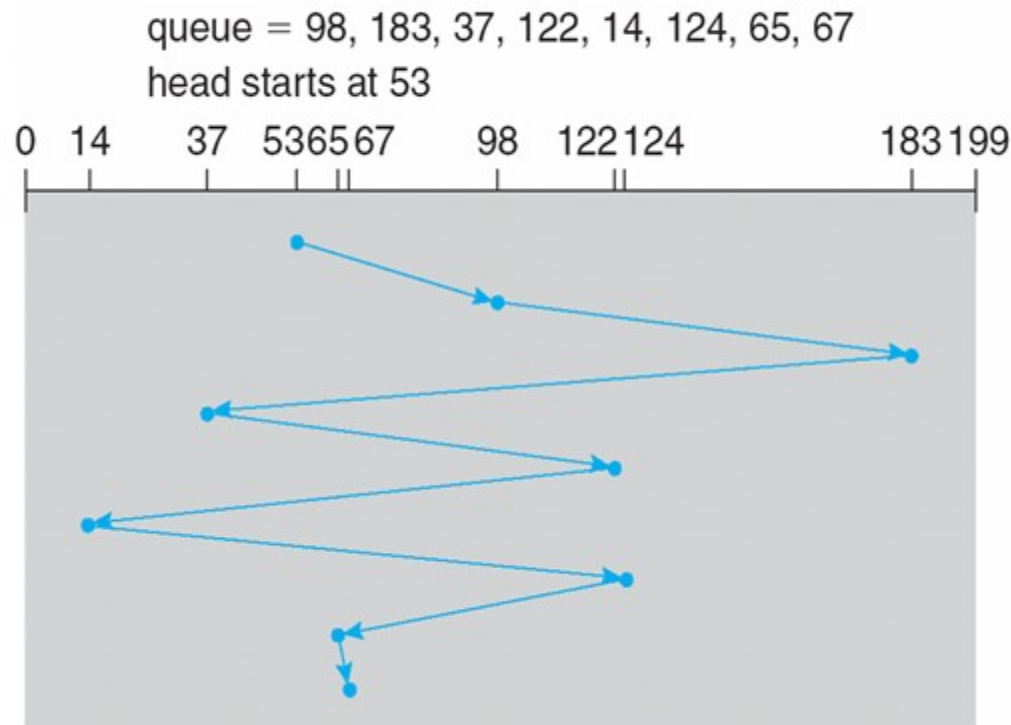

Disk Scheduling algorithms

- Shortest Seek Time First : SSTF

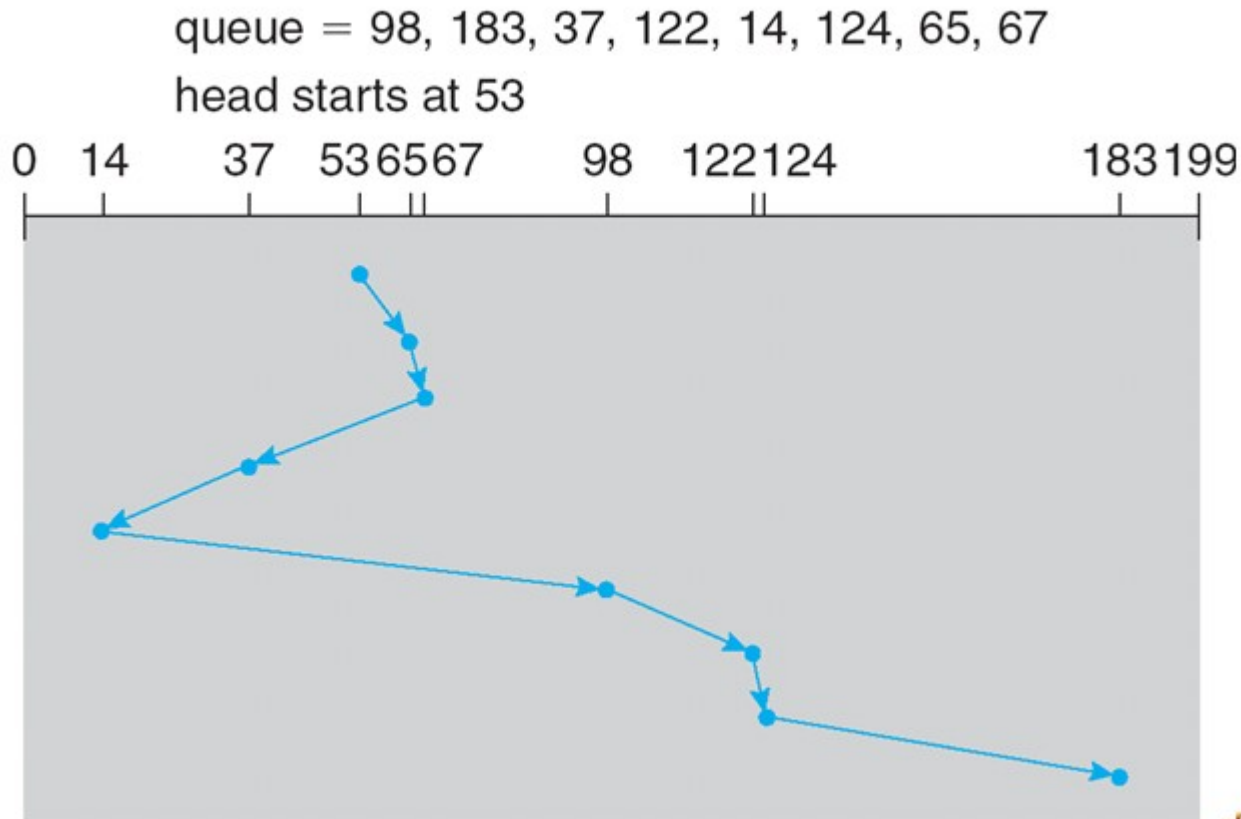

Disk Scheduling algorithms

- SCAN

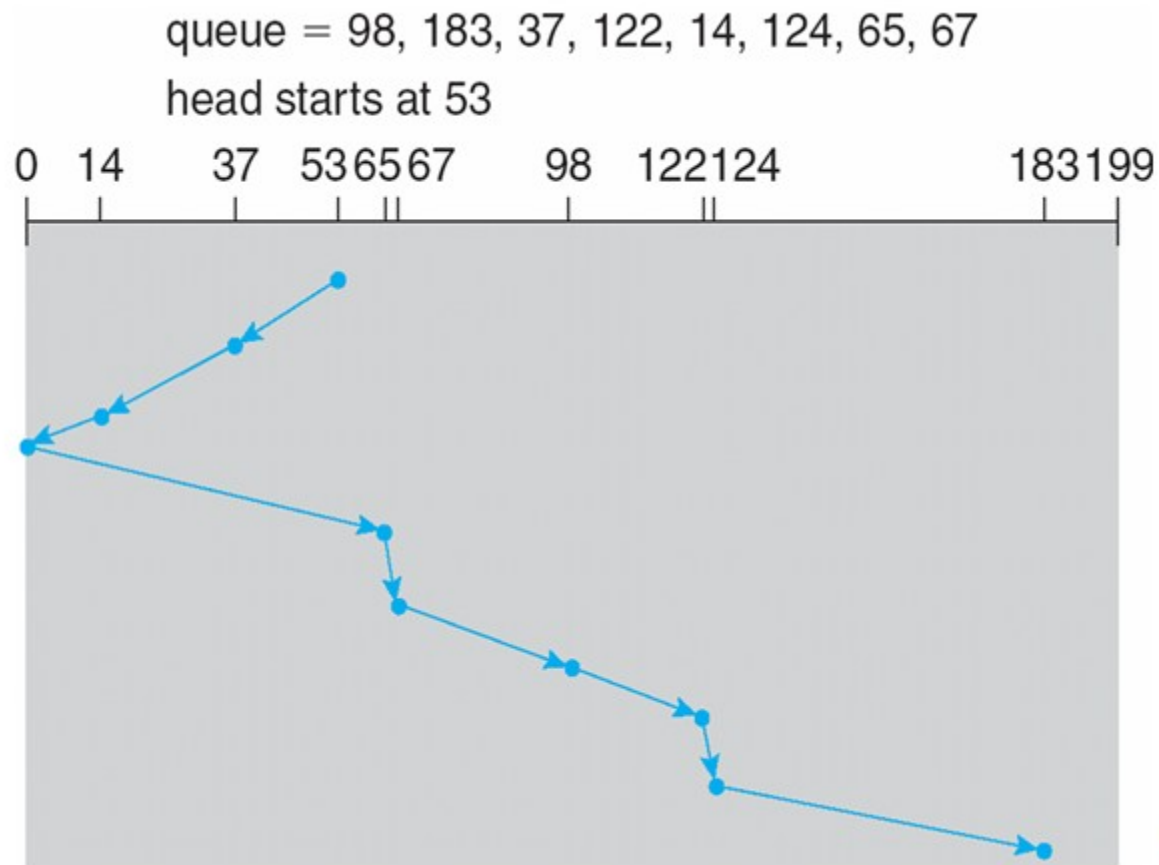

Disk Scheduling algorithms

- Circular SCAN (C-SCAN)

queue = 98, 183, 37, 122, 14, 124, 65, 67
head starts at 53

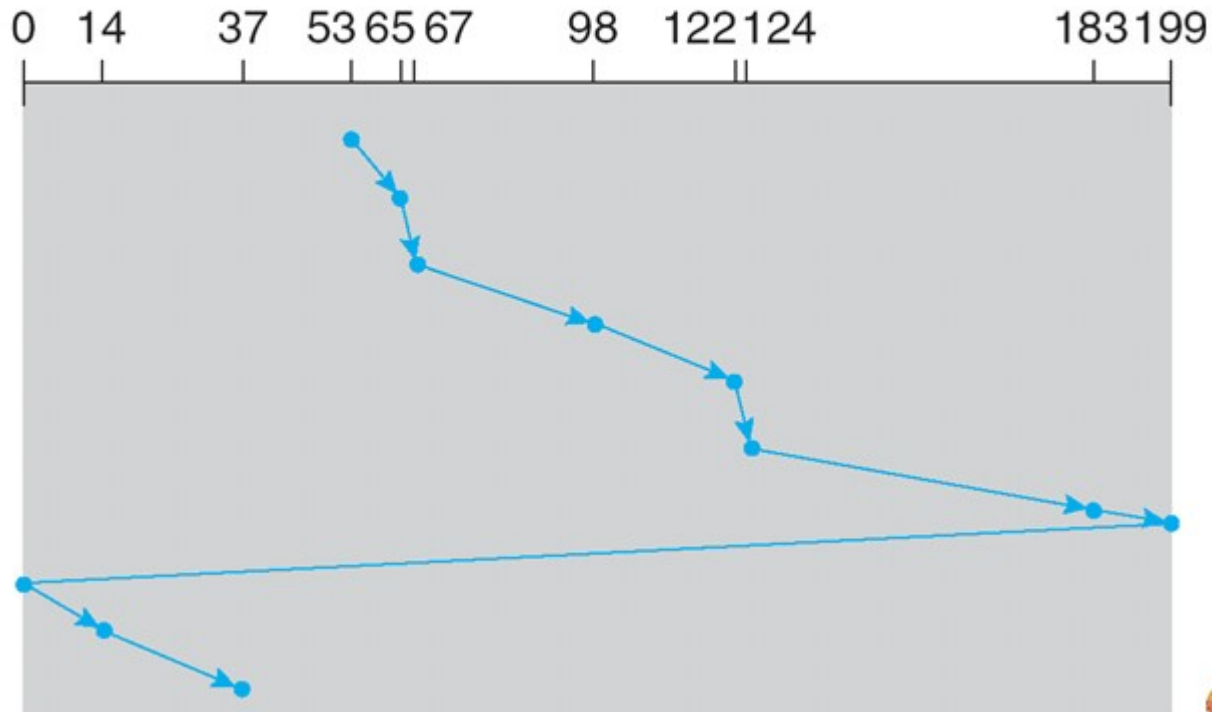

Disk Scheduling algorithms

- LOOK & C-LOOK

